



# Logo Usage Guide

Version 2.0

## Contents

---

Overview	3
Scale, Structure and Spacing	4
Colors: Offline and Online	9
Colors: Grayscale	10
Colors: One-color	11
Colors: Background	12
Fonts	13
Improper Uses (Do's and Don'ts)	14

## Overview

---



The IAC Corporate logo and sector/segment logos are core components of the IAC brand. This document explains and outlines their proper use.

## Scale, Structure and Spacing

---

### Scale

#### *IAC Sector/Segment Logos*



The total height of individual sector/segment logos varies depending on the length of their names (some include a second line) and the presence of letters with descenders (g, j, p, q, and y) within those names.

A relationship that remains constant regardless of the total height of any given logo is the cap height (height of an uppercase letter) of *IAC* to the cap height of the font used in the sector/segment name. The cap height of the sector/segment name is 71% of the cap height of *IAC*.

## Scale, Structure and Spacing [continued]

### Structure

*IAC Corporate Logo and IAC Sector/Segment Logos*

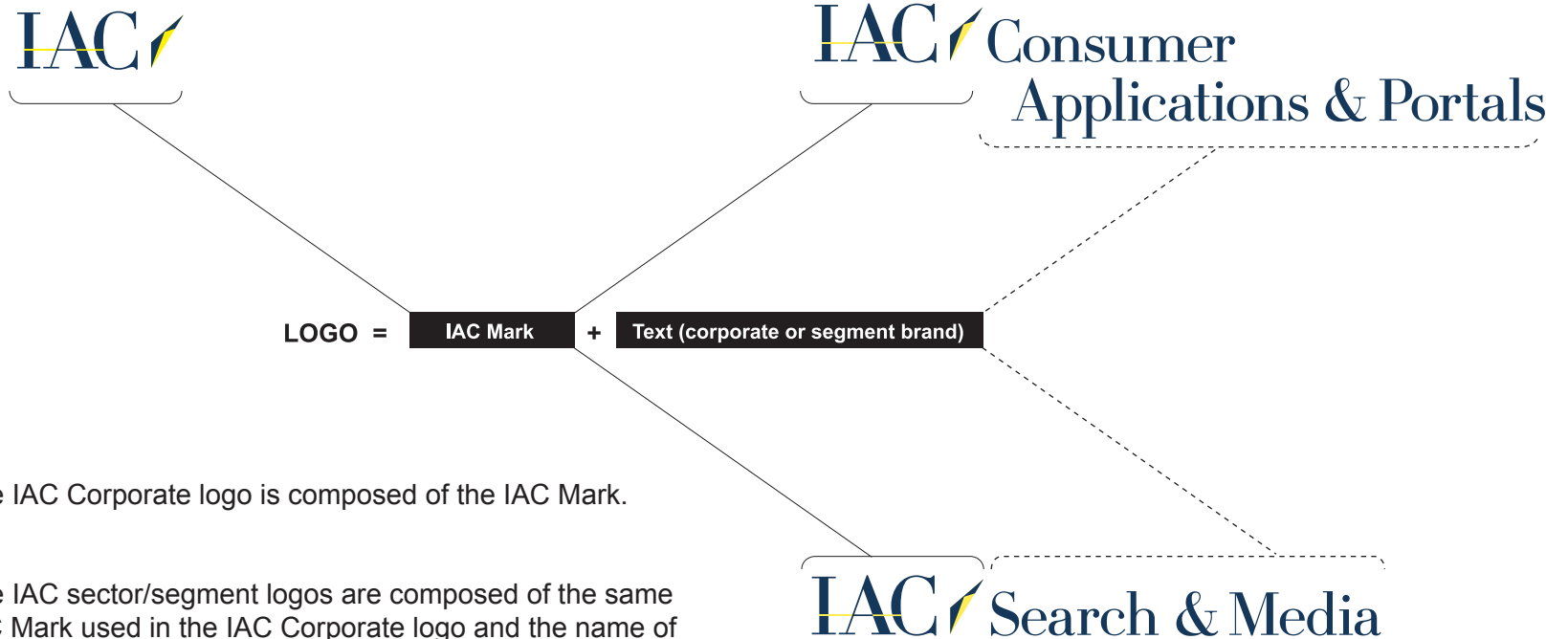

The IAC Corporate logo is composed of the IAC Mark.

The IAC sector/segment logos are composed of the same IAC Mark used in the IAC Corporate logo and the name of the sector/segment. The sector/segment name appears as either a single line or two lines for longer names.

## Scale, Structure and Spacing [continued]

---

### *IAC Corporate Logo*

The I, A and C in the IAC Mark are always uppercase.



### *IAC Advertising Solutions*

All words in sector/segment names are capitalized (word begins with an uppercase letter). For this segment, A in *Advertising* and S in *Solutions* are always uppercase. This rule applies for all sector/segment names below.



### *IAC Consumer Applications & Portals*

*Consumer* always appears on the first line followed by *Applications & Portals* on the second line, with a double space before *Applications*. All words in segment names are capitalized (word begins with an uppercase letter).



### *IAC Search & Media*

*Search & Media* always appears fully on the same line and never separated by a line break. All words in segment names are capitalized (word begins with an uppercase letter).



### *IAC Political Action Committee*

*Committee* always appears on a second line and after a double space. All words in segment names are capitalized (word begins with an uppercase letter).



## Scale, Structure and Spacing [continued]

### Spacing

#### *IAC Corporate Logo*

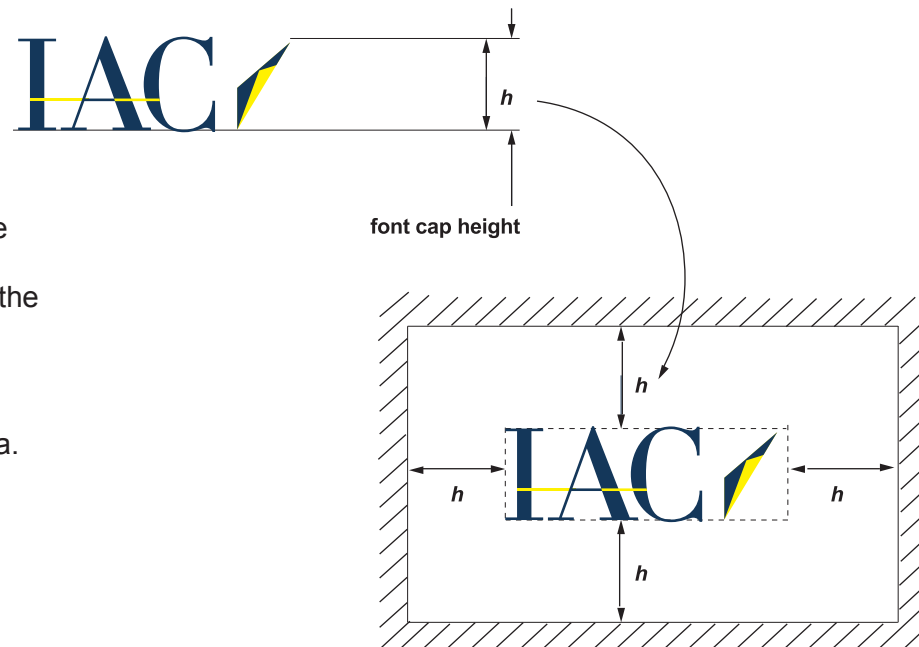

The IAC corporate logo should have a margin of clear space on all sides around it equal to the cap height of the IAC font (shown as  $h$ ).

No objects (text, images, or other logos) can appear inside of this area.

## Scale, Structure and Spacing [continued]

### Spacing

#### IAC Sector/Segment Logos

All sector/segment logos must have a clear margin around them also equal to  $h$  (the cap height of the *IAC Mark* font and shown previously).

For the bottom margin,  $h$  is measured from the baseline of the font on the lowest line of text.

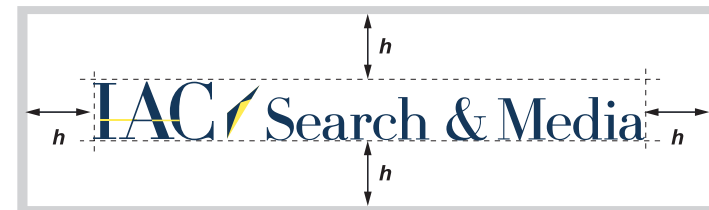
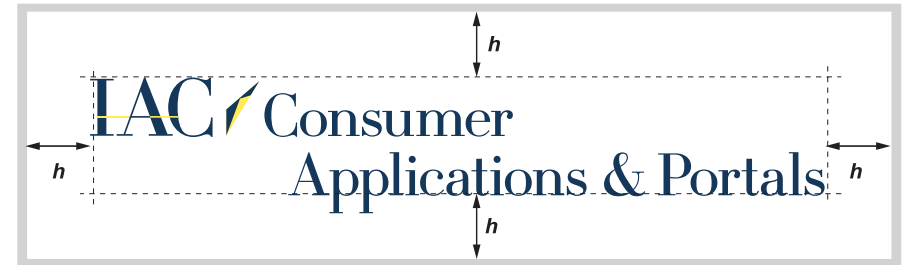

Sector/segment names that require a second line of text have a leading (or line-height) setting equivalent to 92% of the font size.

The first word that appears on the second line of a segment name is always preceded by a double space.

## Colors: Offline and Online

---

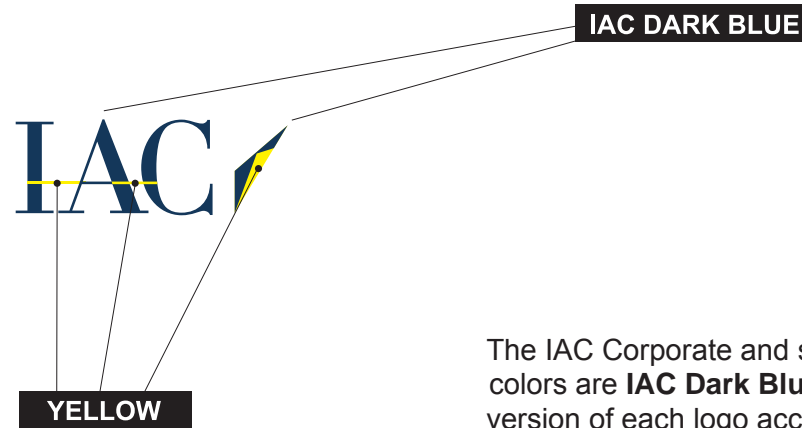

The IAC Corporate and sector/segment brand logo colors are **IAC Dark Blue** and **Yellow**. Use the appropriate version of each logo according to the type of application.

### Print: Process

For four-color process (CMYK) print jobs, use the appropriate version of the logo with the color values below.

IAC DARK BLUE	CMYK <b>100, 64, 0, 60</b>
---------------	-------------------------------

YELLOW	CMYK <b>0, 0, 100, 0</b>
--------	-----------------------------

### Print: Spot

For spot color print jobs, use the appropriate version of the logo with the color values below.

IAC DARK BLUE	PMS <b>289 BLUE</b>
---------------	------------------------

YELLOW	PMS <b>PANTONE YELLOW</b>
--------	------------------------------

### Online

For any online or screen applications, use the version of the logo with the color values below.

IAC DARK BLUE	RGB <b>0, 0, 51</b> HEX <b>000033</b>
---------------	--

YELLOW	RGB <b>255, 255, 0</b> HEX <b>FFFF00</b>
--------	---

## Colors: Grayscale

---

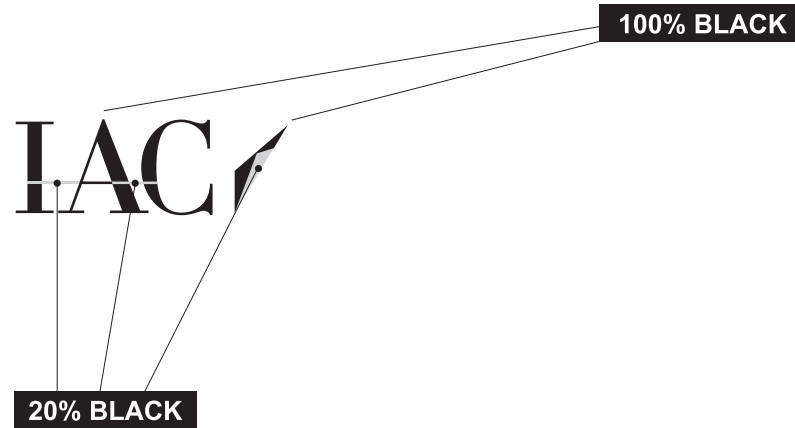

### Print: Grayscale

For high resolution black and white printing, use the appropriate version of the logo with the color substitution values below.

---

IAC DARK BLUE	<b>100% BLACK</b>
---------------	-------------------

---

YELLOW	<b>20% BLACK</b>
--------	------------------

---

**Colors: One-color**

---

**Print: One-color**

For spot color print jobs or low resolution applications such as use in fax forms, use the appropriate version of the logo set entirely in black.

## Colors: Background

---



### Logo on a dark background

A one-color all-white version of the logo is used on dark backgrounds. A colored version of the logo must not be used because the contrast of yellow against white text is too subtle.



### Logo on a light background

A colored version of the logo can be used over light backgrounds with low color saturation.

If used over a non-solid background (like a photograph or shaded field of color such as a gradient), special care must be given to placement. The logo must not be placed over areas of high relative contrast.

## Fonts

---

**IAC Regular** ABCDEFGHIJKLMNOPQRSTUVWXYZ  
& abcdefghijklmnopqrstuvwxyz

The segment name type in all logos is set in IAC Regular.

Uppercase and lowercase letters are used. All words in segment names are capitalized (all words begin with an uppercase letter).

The ampersand (&) is the only punctuation character permitted.

Segment logos have variable tracking, set according to length and visual characteristics of each logo. Tracking and kerning settings in existing logos must not be modified.

**IAC** Advertising Solutions  
← tight tracking →

**IAC** Political Action  
Committee  
← tighter tracking →

## Improper Uses(Do's and Don'ts)

---



**DO NOT** rearrange elements in the logo



**DO NOT** treat any IAC logo as a sub-brand



**PROPER USE**

Always use an original version of the logo without alterations

## Improper Uses(Do's and Don'ts) [continued]

---

~~IAC Advertising Solutions~~

**DO NOT** scale beyond a reasonable size

IAC Advertising Solutions

**PROPER USE:** Scale sensibly so that all words are clearly legible

~~IAC Search & Media~~

~~IAC Search & Media~~

**DO NOT** scale disproportionately

IAC Search & Media

IAC Search & Media

**PROPER USE:** Scale proportionally (equal change on both axes)

~~IAC advertising solutions~~

**DO NOT** alter capitalization in any logo

IAC Advertising Solutions

**PROPER USE:** Always use original logos without alterations

~~IAC Consumer Applications  
& Portals~~

**DO NOT** change word placement or position

IAC Consumer  
Applications & Portals

**PROPER USE:** Always use original logos without alterations

## Improper Uses(Do's and Don'ts) [continued]

---



**DO NOT** change word placement or position



**PROPER USE:** The second line of a segment logo always follows a double space. Always use original logos without alterations



**DO NOT** realign elements in the logo



**PROPER USE:** Always use original logos without alterations